

SMOOTH, PRECISION CUTTING DEPTH CONTROL FOR ALL BTB BLADES

Using BTB's Cutting Depth Control Arms:

- Gives technicians confidence in avoiding damage to painted pinchweld, encapsulated moulding, vehicle body and cutting blades
- Provides precise, adjustable blade cutting depth control
- Provides a smooth cut, with wheels rolling easily along all surfaces
- Provides stability for ORANGE "R" reverse blades when safely removing encapsulated glasses as blade reciprocates against pinchweld / body panel



WK11AW - Roller Wheel Blade Depth Control Arm



- Thin 1mm wheel
- Use **over** YELLOW "Z" blades and WK3 & WK4 blades
- Wheel rolls smoothly along uneven (in & out) urethane surface.



WK11AW arm **over** WK4ZS blade

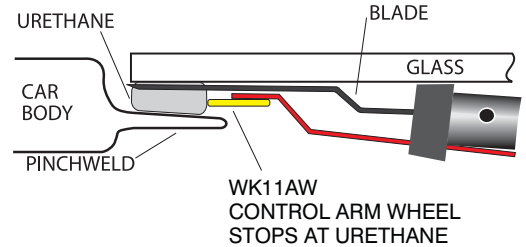

WK11BW5 - Roller Wheel Blade Depth Control Arm



- Large plastic wheel
- Use **over** YELLOW "Z" blades and WK3 & WK4 blades
- Wheel rolls along A-pillar trim, soft headliner or vehicle body panel



WK11BW5 arm **over** WK4ZS blade

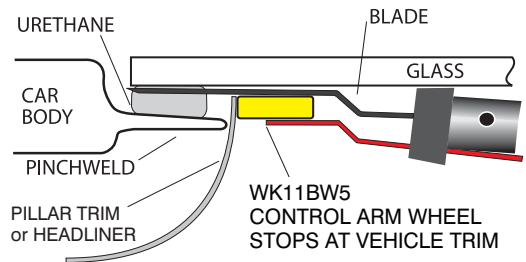

WK11CW - Roller Wheel Blade Depth Control Arm



- Thin 1mm wheel on each end for use with ORANGE reverse blades for removal of encapsulated glasses
- Use long offset end **under** ORANGE WK4R-S blade
- Use short offset end **under** ORANGE WK4ZR-S & WK24ZR-S blades
- Wheel rolls smoothly along uneven (in & out) urethane surface.



WK11CW arm **under** WK4RS blade



WK11CW arm **under** WK24ZRS blade

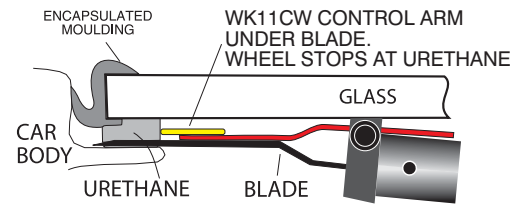

This controller arm spaces the blade away from the glass/encapsulation

The arm provides a support for the blade to avoid any blade flapping or shaking

WK11DW5 - Roller Wheel Blade Depth Control Arm



- Large plastic wheel
- Use **under** WK5 & WK5-S to control blade depth when removing backfill from glass edge (buses & trains)
- Also used to control cutting depth for other flat blades e.g. WK2-S blades for longer reach cutting applications
- Wheel rolls along window glass or vehicle body trim



WK11DW5 arm **under** flat side of WK5S blade



WK11DW5 arm **over** WK2S blade

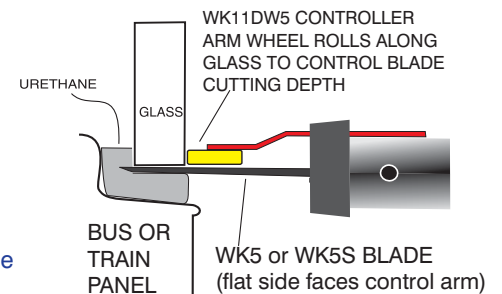

Removing backfill urethane between bus window glasses

The wheeled controller arms provide a smooth flowing cutting action on soft or hard vehicle trims, body panels, glass or urethane

SMOOTH, PRECISION CUTTING DEPTH CONTROL FOR ALL BTB BLADES

Using BTB's Cutting Depth Control Arms:

WK11EW - Roller Wheel Blade Depth Control Arm

- Long arm with Thin 1mm wheel
- Use **over** WK1 & WK1-S long blades
- Excellent to control blade cutting depth for long reach below deep dashboards
- Wheel rolls smoothly along uneven (in & out) urethane surface.



WK11EW arm over WK1S blade

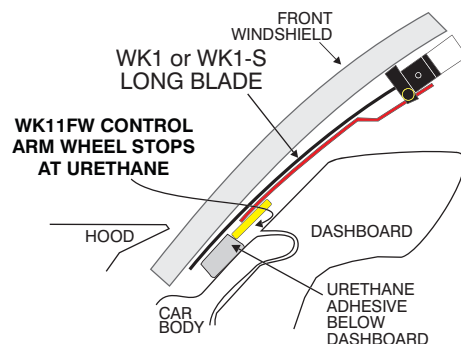

WK11FW - Roller Wheel Blade Depth Control Arm



- Thin 1mm wheel on each end
- Use long end **over** YELLOW WK2, WK2-S, WK24 & WK24-S blades or under ORANGE WK24R-S blade for encapsulated glass removal
- Use short end **over** YELLOW WK3 & WK4 blades or **under** ORANGE WK4R-S blade (for encap glass)
- Wheel rolls smoothly along uneven (in & out) urethane surface.



WK11FW arm over WK2S blade



WK11FW arm under WK24RS blade

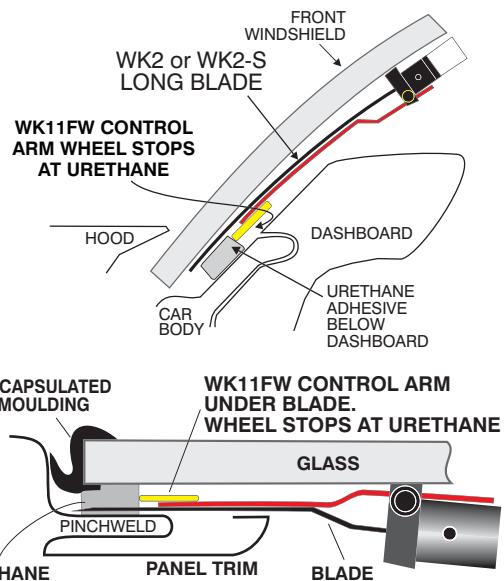

WK11PP - Paint Protector Arm for WK27 & WK28 Powered Cold Knife Blades

- Use with WK27 & WK28 Powered Cold Knife blades **where there is a small space between glass edge and the painted panel**
- Paint protector provides a barrier between blade and painted panel
- Avoid damage to e-coat along the vehicle A-Pillar
- Paint protector stops blade hitting corner of painted panel



WK11PP arm with external cutting WK28 blade

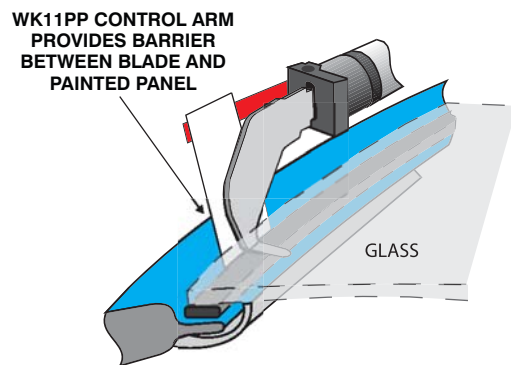

WK26 - Backfill Blade Depth Control Arm

- Use with WK17 blades to control cutting depth when removing backfill between bus or train glasses prior to glass removal
- Non-scratch nylon guide slides along surface of glass or panel to provide cutting depth control



WK26 arm with WK17 blade

SEE WK11DW5 ARM USED WITH WK5-S BLADE FOR ALTERNATE BACKFILL REMOVAL OPTION

